

Safety Standard Certified Resin Molding SMD Type Ceramic Capacitors for automotive SYW Series (Y1:250V~/400V~) 100J~222M _automotive

POE-D45-00-E-01

Ver: 10

Page: 1 / 18

HF

PRODUCT SPECIFICATION

PRODUCT: Safety Standard Certified Resin Molding SMD Type Ceramic Capacitors for automotive

TYPE: SYW SERIES (Y1:250V~/400V~)
100J~222M _automotive

CUSTOMER:

N.W.: 0.2~0.3g/pc

DOC. NO.: POE-D45-00-E-01

APPROVED BY CUSTOMER

VENDOR :

- WALSIN TECHNOLOGY CORPORATION**
566-1, KAO SHI ROAD, YANG-MEI
TAO-YUAN, TAIWAN
- PAN OVERSEAS (GUANGZHOU) ELECTRONIC CO.,LTD.**
NO.277,HONG MING ROAD,EASTERN SECTION,HUANGPU DISTRICT,
GUANG ZHOU,CHINA
- DONGGUAN WALSIN TECHNOLOGY ELECTRONICS CO., LTD.**
NO.638, MEI JING WEST ROAD,XINIUPO,ADMINISTRATIVE ZONE,DAL
ANGTOWN,DONGGUAN CITY, GUANGDONG PROVINCE

PSA

Safety Standard Certified Resin Molding SMD Type Ceramic Capacitors for automotive SYW Series (Y1:250V~/400V~) 100J~222M_automotive	POE-D45-00-E-01	Ver: 10	Page: 2 / 18
---	-----------------	---------	--------------

Record of change

Date	Version	Description	page
2025/2/24	00	First edition.	All
2025/9/9	01	Correct the erroneous content:7.1、7.2、8.1	13~14



Safety Standard Certified Resin Molding SMD Type Ceramic Capacitors for automotive SYW Series (Y1:250V~/400V~) 100J~222M _automotive	POE-D45-00-E-01	Ver: 10	Page: 3 / 18
--	-----------------	---------	--------------

Table of Contents

No.	Item	Page
1	Part number for SAP system	4
2	Mechanical	5
3	Part numbering/T.C/Capacitance/ Tolerance	5
4	Marking	6
5	Scope	7
6	Specification and test method	8~12
7	Packing	13
8	Soldering Recommendation	14
9	Storage conditions	15
10	Caution	16~17
11	Notices	18



Safety Standard Certified Resin Molding SMD Type Ceramic Capacitors for automotive SYW Series (Y1:250V~/400V~) 100J~222M _automotive	POE-D45-00-E-01	Ver: 10	Page: 4 / 18
--	-----------------	---------	--------------

1. Part number for SAP system:

(Ex.) YU S YW 102 M P 0A
 (1) (2) (3) (4) (5) (6)

(1) Temperature characteristic (identified code)

CODE	Temperature characteristic	Cap. Change
SL	SL	-1000~+350PPM/°C (+20°C~+85°C)
YP	B (Y5P)	±10%
YU	E (Y5U)	-56% to +22%
YV	F(Y5V)	-82% to +22%

(2) SMD Type : SYW (Y1:250Vac/400Vac)

(3) Capacitance (identified by 3-figure code):ex. 681=680pF , 102=1000pF , 103=10000pF

(4) Capacitance tolerance (identified by code): J:±5%, K:±10%, M:±20%

(5) Special Specification Code :

Code	Description
P	Pb Solder Product

(6) Internal code: 0A-- safety standard certified ceramic capacitor that meets the requirements of AEC-Q200.



2. Mechanical: Encapsulation : Epoxy resin, flammability UL94 V-0

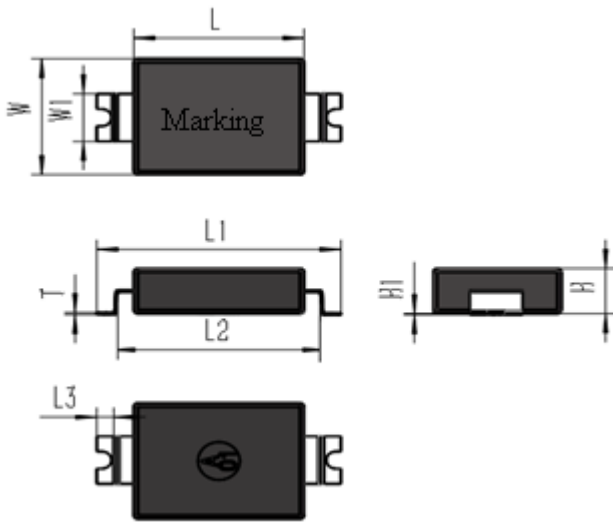





Dimension(mm)			
L	7.8±0.1	W1	2.5±0.1
W	5.4±0.3	T	0.13±0.05
H	2.45 max	H1	0.1+0.1/-0.05
L1	9.6±0.3	L3	0.4 min.
L2	8.4+0.5/-0.2 (inside measure)		

3. Part numbering/T.C/Capacitance/ Tolerance :

SAP P/N	T.C.	Capacitance	Tolerance
SLSYW100JP0A	SL	10 pF	±5%
SLSYW220JP0A		22 pF	
SLSYW330JP0A		33 pF	
SLSYW470JP0A		47 pF	
SLSYW680JP0A		68 pF	
YPSYW101KP0A	Y5P	100 pF	±10%
YPSYW151KP0A		150 pF	
YPSYW221KP0A		220 pF	
YPSYW271KP0A		270 pF	
YPSYW331KP0A		330 pF	
YPSYW471KP0A		470 pF	
YUSYW471MP0A	Y5U	470 pF	±20%
YUSYW681MP0A		680 pF	
YUSYW102MP0A		1000 pF	
YUSYW152MP0A		1500 pF	
YVSYW222MP0A	Y5V	2200 pF	

Safety Standard Certified Resin Molding SMD Type Ceramic Capacitors for automotive SYW Series (Y1:250V~/400V~) 100J~222M _automotive	POE-D45-00-E-01	Ver: 10	Page: 6 / 18
--	-----------------	---------	--------------

4. Marking:

1. Company Name Code(Trade mark)	UK
2. Type/Series Designation	SYW
3. Code of Dielectric	SL / B(Y5P) / E(Y5U) / F(Y5V)
4. Nominal Capacitance	Identified by 3-Figure Code. Ex. 680pF→"681", 1000pF→"102"
5. Capacitance Tolerance	J: ±5%, K:±10%, M:±20%
6. Class code/Rated Voltage Mark	Y1 / 250V~: voltage for KC ;400V~: voltage for UL CQC ENEC
7. Safety certification mark	UL/cUL:  us ; ENEC:  ; CQC:  ; KC: 
8. Products ID (Manufactured Date code, add as needed)	Abbreviation ex.: SB011115-AU S: year 2024 B: Sn-Pb-Ag Solder 01: Machine and batch (production line traceability) 11: month November 15:date 15 th -AU: Safety standard certified ceramic capacitor for Automotive
Marking sample	
	

Date code comparison table:

code of year		code of month		code of day					
year	code	year	code	month	code	day	code	day	code
		2020	M	1	1	1	1	16	16
		2021	N	2	2	2	2	17	17
2010	A	2022	P	3	3	3	3	18	18
2011	B	2023	R	4	4	4	4	19	19
2012	C	2024	S	5	5	5	5	20	20
2013	D	2025	T	6	6	6	6	21	21
2014	E	2026	U	7	7	7	7	22	22
2015	F	2027	V	8	8	8	8	23	23
2016	H	2028	W	9	9	9	9	24	24
2017	J	2029	X	10	10	10	10	25	25
2018	K			11	11	11	11	26	26
2019	L			12	12	12	12	27	27
						13	13	28	28
						14	14	29	29
						15	15	30	30
								31	31

Safety Standard Certified Resin Molding SMD Type Ceramic Capacitors for automotive SYW Series (Y1:250V~/400V~) 100J~222M_automotive	POE-D45-00-E-01	Ver: 10	Page: 7 / 18
---	-----------------	---------	--------------

5. Scope:

This specification is applied to following safety standard certified ceramic capacitor. And meets the requirements of AEC-Q200. It can be used for the battery charger for Electric Vehicles and Plug-in Hybrid.

5.1 Safety standards approval and recognized no.

	Standard No.	Subclass	w.v.	Recognized No.
UL / CUL	ANSI/UL 60384-14	Y1	250Vac/400Vac	E146544
ENEC	EN 60384-14:2013/A1:2016	Y1	250Vac/400Vac	ENEC-03633-M1
CQC	GB/T6346.14	Y1	400Vac	CQC21001310797
KC	K60384-14	Y1	250Vac	SU03127-21001

5.2. Content of toxic and harmful substances control requirements

RoHS2.0 2011/65/EU、Halogen、REACH No1907/2006

5.3 Exemption Clause

2010/571/EU 7(a) : Lead in high melting temperature type solders (i.e. lead-based alloys containing 85 % by weight or more lead)

5.4 Product Structure:

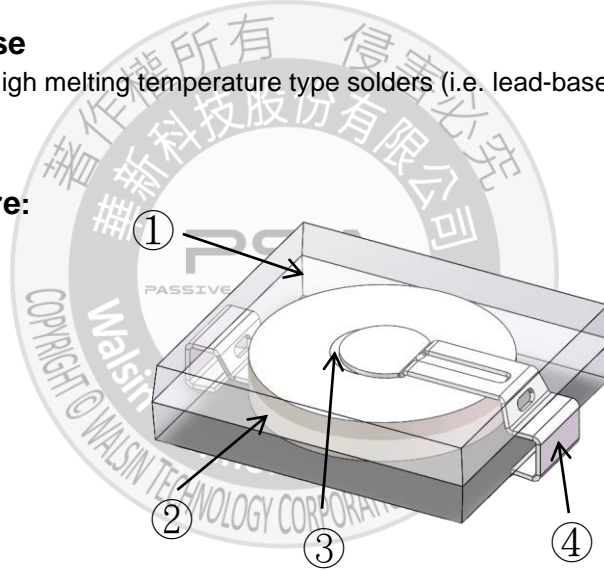

No.	Part name	Material
①	Coating	Epoxy molding compound (Conforming to UL94V-0 standard)
②	Chip	Ceramic chip
③	Solder	Sn-Pb-Ag Solder
④	Lead pin	Copper alloy
		Tin coating

Safety Standard Certified Resin Molding SMD Type Ceramic Capacitors for automotive SYW Series (Y1:250V~/400V~) 100J~222M _automotive	POE-D45-00-E-01	Ver: 10	Page: 8 / 18
--	-----------------	---------	--------------

6. Specification and test method:

6.1 Operating Temperature Range: -40 to +125°C

6.2 Test condition:

Test and measurement shall be made at the standard condition. (temperature 15~35°C, relative humidity 45~75% and atmospheric pressure 860~1060hpa). Unless otherwise specified herein.

If doubt occurred on the value of measurement, and measurement was requested by customer capacitors shall be measured at the reference condition. (temperature 20±2°C or 25 ± 2°C, relative humidity 60~70% and atmospheric pressure 860~1060hpa.)

6.3 Performance:

No	Items	Specification	Testing method																						
1	Appearance and dimensions	No marked defect on appearance form and dimensions. Please refer to [Part number list].	The capacitor should be inspected by naked eyes for visible evidence of defect. Dimensions should be measured with slide calipers.																						
2	Marking	To be easily legible.	The capacitor should be inspected by naked eyes.																						
3	Voltage proof (Dielectric strength)	Between lead pin	When AC4000V (r. m.s.)<50/60Hz>and DC5000V are applied between wires for 60s, the capacitor should not be damaged. (Charging/discharging currents≤50mA) AC4000V(r.m.s.)<50/60Hz>60 s. (充电/放电电流≤50mA) First, the terminals of the capacitor should be connected together. Then, a metal foil should be closely wrapped around the body of the capacitor to the distance of about 3 to 4mm from each terminal. Finally, AC4000V (r.m.s.)<50/60Hz> is applied for 60 s between the capacitor lead wires and metal balls. (Charge/Discharge current ≤ 50mA)																						
		Body Insulation																							
4	Capacitance	Within specified tolerance J: ±5% K: ±10% M: ±20%	Temperature:25±3°C Humidity: 55±30%RH																						
5	Dissipation Factor(D.F.)	<table border="1"> <thead> <tr> <th>Char.</th> <th>Specifications</th> </tr> </thead> <tbody> <tr> <td>SL</td> <td>1.5% max.</td> </tr> <tr> <td>B(Y5P) E(Y5U) F(Y5V)</td> <td>2.5% max.</td> </tr> </tbody> </table>	Char.	Specifications	SL	1.5% max.	B(Y5P) E(Y5U) F(Y5V)	2.5% max.	<table border="1"> <thead> <tr> <th>Material</th> <th>Frequency</th> <th>Voltage</th> </tr> </thead> <tbody> <tr> <td>SL</td> <td>1±0.1 MHz</td> <td rowspan="4">1.0+0.2Vrms</td> </tr> <tr> <td>B(Y5P)</td> <td rowspan="3">1±0.1 KHz</td> </tr> <tr> <td>E(Y5U)</td> </tr> <tr> <td>F(Y5V)</td> </tr> </tbody> </table>	Material	Frequency	Voltage	SL	1±0.1 MHz	1.0+0.2Vrms	B(Y5P)	1±0.1 KHz	E(Y5U)	F(Y5V)						
Char.		Specifications																							
SL	1.5% max.																								
B(Y5P) E(Y5U) F(Y5V)	2.5% max.																								
Material	Frequency	Voltage																							
SL	1±0.1 MHz	1.0+0.2Vrms																							
B(Y5P)	1±0.1 KHz																								
E(Y5U)																									
F(Y5V)																									
6	Temperature Characteristic	(Temp. range : -25 to +85°C) <table border="1"> <thead> <tr> <th>Char.</th> <th>Capacitance Change</th> </tr> </thead> <tbody> <tr> <td>SL</td> <td>:+350~-1000(ppm/°C)</td> </tr> <tr> <td>B(Y5P)</td> <td>Within ± 10%</td> </tr> <tr> <td>E(Y5U)</td> <td>Within +22/-56%</td> </tr> <tr> <td>F(Y5V)</td> <td>Within +22/-82%</td> </tr> </tbody> </table>	Char.	Capacitance Change	SL	:+350~-1000(ppm/°C)	B(Y5P)	Within ± 10%	E(Y5U)	Within +22/-56%	F(Y5V)	Within +22/-82%	The capacitance measurement shall be made at each step specified in Table Pre-treatment : The capacitor should be stored at 125 ± 3°C for 1 hour and subjected to AC4000V (r.m.s.) for 60 seconds. Then, it should be left at room temperature for 24 ± 2 hours before initial measurement. <table border="1"> <thead> <tr> <th>Step</th> <th>1</th> <th>2</th> <th>3</th> <th>4</th> <th>5</th> </tr> </thead> <tbody> <tr> <td>Temp.(°C)</td> <td>+20±2</td> <td>-25±2</td> <td>+20±2</td> <td>+85±2</td> <td>+20±2</td> </tr> </tbody> </table> $\Delta = (C_x - C_0) / C_0$ Cx capacitor for step 2,4 C0 capacitor for step 3	Step	1	2	3	4	5	Temp.(°C)	+20±2	-25±2	+20±2	+85±2	+20±2
Char.	Capacitance Change																								
SL	:+350~-1000(ppm/°C)																								
B(Y5P)	Within ± 10%																								
E(Y5U)	Within +22/-56%																								
F(Y5V)	Within +22/-82%																								
Step	1	2	3	4	5																				
Temp.(°C)	+20±2	-25±2	+20±2	+85±2	+20±2																				
7	Insulation resistance	10000MΩ min.	The insulation resistance shall be measured with DC500±50V within 60±5s of charging. The voltage should be applied to the capacitor through a resistor of 1MΩ.																						

Safety Standard Certified Resin Molding SMD Type Ceramic Capacitors for automotive SYW Series (Y1:250V~/400V~) 100J~222M _automotive	POE-D45-00-E-01	Ver: 10	Page: 9 / 18
--	-----------------	---------	--------------

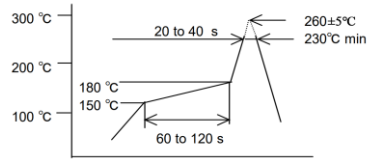
No	Items	Specification	Testing method															
8	Solderability	Good tin coating (tin rate above 90%), within 3 seconds of convergence..	Immerse the capacitor in the solution of ethanol (JIS K 8101) and rosin (JIS K 5902) (25% rosin in weight proportion). (Reference) Bath temperature: 245±5℃ Immersion time: 5±0.5seconds Depth of immersion(from the seating plane or component body)															
9	Soldering Heat Resistance	Appearance	Reflow(peak)Solder temperature : 260±5℃ Solder zone : 230℃ min. 20-40s Pre-treatment  The capacitor should be stored at 125 ± 3℃ for 1 hour and subjected to AC4000V (r.m.s.) for 60 seconds. Then, it should be left at room temperature for 24 ± 2 hours before initial measurement Post-treatment: Capacitor should be stored for 24±2h at *room condition.															
		Insulation resistance		1000MΩ min.														
		Voltage proof (Dielectric Strength)		refer item 3														
		Dissipation factor		SL:1.5% max Y5P/Y5U/Y5V: 2.5% max														
		Capacitance Change		SL : ±5% Y5P: ±10% Y5U、Y5V: ±20%														
10	Vibration	Appearance	Solder the capacitor and gum up the body to the test jig (glass epoxy board) by resin(adhesive). The capacitor should be firmly soldered to the supporting lead wire, 1.5mm in total amplitude, with about 20 minutes rate of vibration change from 10Hz to 2000Hz and back to 10Hz This motion should be applied for 12 times in each 3 mutually perpendicular directions (total of 36 times). The acceleration is 5g max.															
		Capacitance change		SL : ±5% Y5P: ±10% Y5U、Y5V: ±20%														
		Dissipation factor		SL:1.5% max Y5P/Y5U/Y5V: 2.5% max														
		Insulation resistance		≥10000MΩ														
		Voltage proof (Dielectric Strength)		refer item 3														
11	Temperature cycle	Appearance	Pre-treatment : The capacitor should be stored at 125 ± 3℃ for 1 hour and subjected to AC4000V (r.m.s.) for 60 seconds. Then, it should be left at room temperature for 24 ± 2 hours before initial measurement Number of cycles :1000 <table border="1" data-bbox="986 1406 1471 1599"> <thead> <tr> <th>Step</th> <th>Temperature(℃)</th> <th>Time</th> </tr> </thead> <tbody> <tr> <td>1</td> <td>-55+0/-3</td> <td>15+3/-0min</td> </tr> <tr> <td>2</td> <td>Room temp.</td> <td>1 min</td> </tr> <tr> <td>3</td> <td>+125+3/-0</td> <td>15+3/-0min</td> </tr> <tr> <td>4</td> <td>Room temp.</td> <td>1 min</td> </tr> </tbody> </table> Post-treatment :Capacitor should be stored for 24±2 h at *room condition.	Step	Temperature(℃)	Time	1	-55+0/-3	15+3/-0min	2	Room temp.	1 min	3	+125+3/-0	15+3/-0min	4	Room temp.	1 min
		Step		Temperature(℃)	Time													
		1		-55+0/-3	15+3/-0min													
		2		Room temp.	1 min													
		3		+125+3/-0	15+3/-0min													
4	Room temp.	1 min																
Voltage proof (Dielectric Strength)	refer item 3																	
Capacitance	SL : ±10% Y5P: ±15% Y5U/Y5V: ±20%																	
Dissipation factor	SL:1.5% max Y5P/Y5U/Y5V: 5.0% max																	
Insulation resistance	≥3000MΩ																	
12	Life (Endurance)	Appearance	Each individual capacitor should be subjected to a 8kV impulses for three times. Then the capacitors are applied to life test The capacitors are placed in a circulating air oven for a period of 1000 h.The air in the oven is maintained at a temperature of 125+2/-0℃, and relative humidity of 50% max.Throughout the test, the capacitors are subjected to a 1.7UR(r.m.s.)<50/60Hz> alternating voltage of mains frequency, except that once each hour the voltage is increased to AC1000V(r.m.s.) for 0.1 s. Pre-treatment :The capacitor should be stored at 125 ± 3℃ for 1 hour and subjected to AC4000V (r.m.s.) for 60 seconds. Then, it should be left at room temperature for 24 ± 2 hours before initial measurement Post-treatment: Capacitor should be stored for 24±2 h at *room condition.															
		Voltage proof (Dielectric Strength)		refer item 3														
		Capacitance change		SL : ±10% Y5P: ±15% Y5U/Y5V: ±20%														
		Dissipation factor		SL:1.5% max Y5P/Y5U/Y5V: 5.0% max														
		Insulation resistance		≥3000MΩ														

Safety Standard Certified Resin Molding SMD Type Ceramic Capacitors for automotive SYW Series (Y1:250V~/400V~) 100J~222M _automotive	POE-D45-00-E-01	Ver: 10	Page: 10 / 18
--	-----------------	---------	---------------

No	Items	Specification	Testing method
13	Mechanical Shock	Appearance	No marked defect.
		Voltage proof (Dielectric Strength)	Per Item 3
		Capacitance Change	$\Delta=(C_x-C_0)/C_0$ SL : $\pm 5\%$ Y5P: $\pm 10\%$ Y5U、Y5V: $\pm 20\%$
		Dissipation factor	SL:1.5% max Y5P/Y5U/Y5V: 5.0% max
		Insulation resistance	$\geq 10000M\Omega$
14	Humidity (Under steady state)	Appearance	No marked defect.
		Voltage proof (Dielectric Strength)	Per Item 3
		Capacitance Change	$\Delta=(C_x-C_0)/C_0$ SL : $\pm 10\%$ Y5P: $\pm 15\%$ Y5U、Y5V: $\pm 20\%$
		Dissipation factor	SL:1.5% max Y5P/Y5U/Y5V: 5.0% max
		Insulation resistance	$\geq 3000M\Omega$
15	High Temperature Exposure (Storage)	Appearance	No marked defect.
		Voltage proof (Dielectric Strength)	Per Item 3
		Capacitance Change	$\Delta=(C_x-C_0)/C_0$ SL : $\pm 10\%$ Y5P: $\pm 15\%$ Y5U、Y5V: $\pm 20\%$
		Dissipation factor	SL:1.5% max Y5P/Y5U/Y5V: 5.0% max
		Insulation resistance	$\geq 1000M\Omega$
16	Humidity loading	Appearance	No marked defect.
		Voltage proof (Dielectric Strength)	Per Item 3
		Capacitance Change	$\Delta=(C_x-C_0)/C_0$ SL : $\pm 10\%$ Y5P: $\pm 15\%$ Y5U、Y5V: $\pm 20\%$
		Dissipation factor	SL:1.5% max Y5P/Y5U/Y5V: 5.0% max
		Insulation resistance	$\geq 3000M\Omega$
17	Humidity Bias	Appearance	No marked defect.
		Voltage proof (Dielectric Strength)	Per Item 3
		Capacitance Change	$\Delta=(C_x-C_0)/C_0$ SL : $\pm 10\%$ Y5P: $\pm 15\%$ Y5U、Y5V: $\pm 20\%$
		Dissipation factor	SL:1.5% max Y5P/Y5U/Y5V: 5.0% max
		Insulation resistance	$\geq 3000M\Omega$

Safety Standard Certified Resin Molding SMD Type Ceramic Capacitors for automotive SYW Series (Y1:250V~/400V~) 100J~222M _automotive		POE-D45-00-E-01	Ver: 10	Page: 11 / 18
--	--	-----------------	---------	---------------

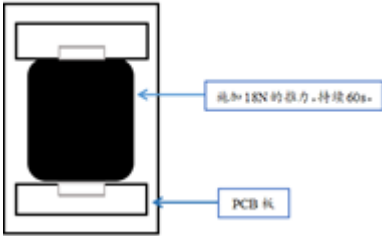
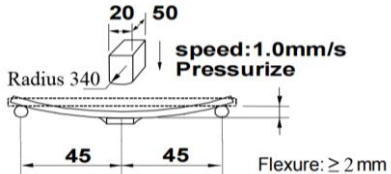
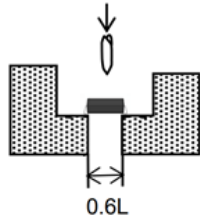
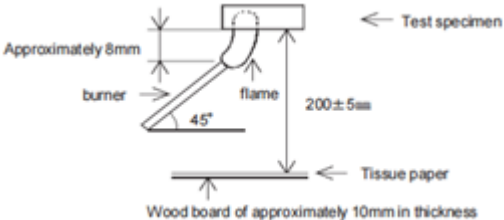
No	Items		Specification	Testing method
18	Adhesive strength of termination	Appearance	No marked defect.	As shown in the figure, solder the capacitor onto the PCB and apply a force of 18N in the direction of the arrow for 60 seconds. 
		Capacitance Change	$\Delta=(C_x-C_0)/C_0$ SL : $\pm 5\%$ Y5P: $\pm 10\%$ Y5U、Y5V: $\pm 20\%$	
		Dissipation factor	SL:1.5% max Y5P/Y5U/Y5V: 5.0% max	
		Insulation resistance	$\geq 1000M\Omega$	
19	Board Flex	Appearance	No marked defect.	As shown in the figure, solder the capacitor onto the PCB and increase the pressure in the direction of the arrow. Boosting speed V=1.0mm/s.Press at least 2mm deep for 60 seconds. 
		Capacitance Change	$\Delta=(C_x-C_0)/C_0$ SL : $\pm 5\%$ Y5P: $\pm 10\%$ Y5U、Y5V: $\pm 20\%$	
		Dissipation factor	SL:1.5% max Y5P/Y5U/Y5V: 5.0% max	
20	Beam Load (Break Strength) Test		The damage value should be greater than 50 N	As shown in the figure, place the capacitor in the beam load fixture. Apply a force. Speed supplied the Stress Load :2.5 mm/s 
21	Passive flammability		The burning time should not be exceeded the time 10s. The tissue paper should not ignite	The capacitor under test shall be held in the flame in the position which best promotes burning. Each specimen shall only be exposed once to the flame. Time of exposure to flame : 20 s Length of flame : 12 \pm 1mm Gas burner : Length 35mm min. Inside dia : 0.5 \pm 0.1mm Outside dia : 0.9mm max. Gas : Butane gas purity 95% min. 
22	Resistance to Solvents	Appearance	No marked defect.	Per MIL-STD-202 Method 215 Solvent 1 : 1 part (by volume) of isopropyl alcohol 3 parts (by volume) of mineral spirits Solvent 2 : Terpene defluxer Solvent 3 : 42 parts (by volume) of water 1part (by volume) of propylene glycol monomethyl ether 1 part (by volume) of monoethanolamine
		Voltage proof (Dielectric Strength)	Per Item 3	
		Capacitance Change	$\Delta=(C_x-C_0)/C_0$ SL : $\pm 5\%$ Y5P: $\pm 10\%$ Y5U、Y5V: $\pm 20\%$	
		Dissipation factor	SL:1.5% max Y5P/Y5U/Y5V: 5.0% max	
		Insulation resistance	$\geq 3000M\Omega$	

Safety Standard Certified Resin Molding SMD Type Ceramic Capacitors for automotive SYW Series (Y1:250V~/400V~) 100J~222M _automotive	POE-D45-00-E-01	Ver: 10	Page: 12 / 18
--	-----------------	---------	---------------

No	Items	Specification	Testing method	
23	ESD	Appearance	Per AEC-Q200-002	
		Capacitance Change		$\Delta=(C_x-C_0)/C_0$ SL : $\pm 5\%$ Y5P: $\pm 10\%$ Y5U、Y5V: $\pm 20\%$
		Dissipation factor		SL: 1.5% max Y5P/Y5U/Y5V: 5.0% max
		Insulation resistance		$\geq 1000M\Omega$

"room condition" Temperature: 15 to 35°C, Relative humidity: 45 to 75%, Atmospheric pressure: 86 to 106kPa

6.4.Capacitor temperature characteristic

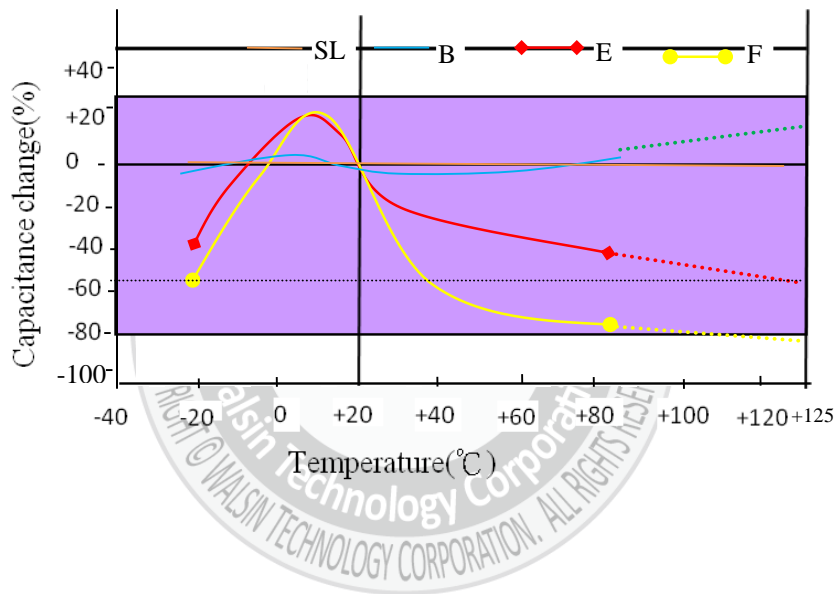

7.Packing :

7.1 Dimension of tape

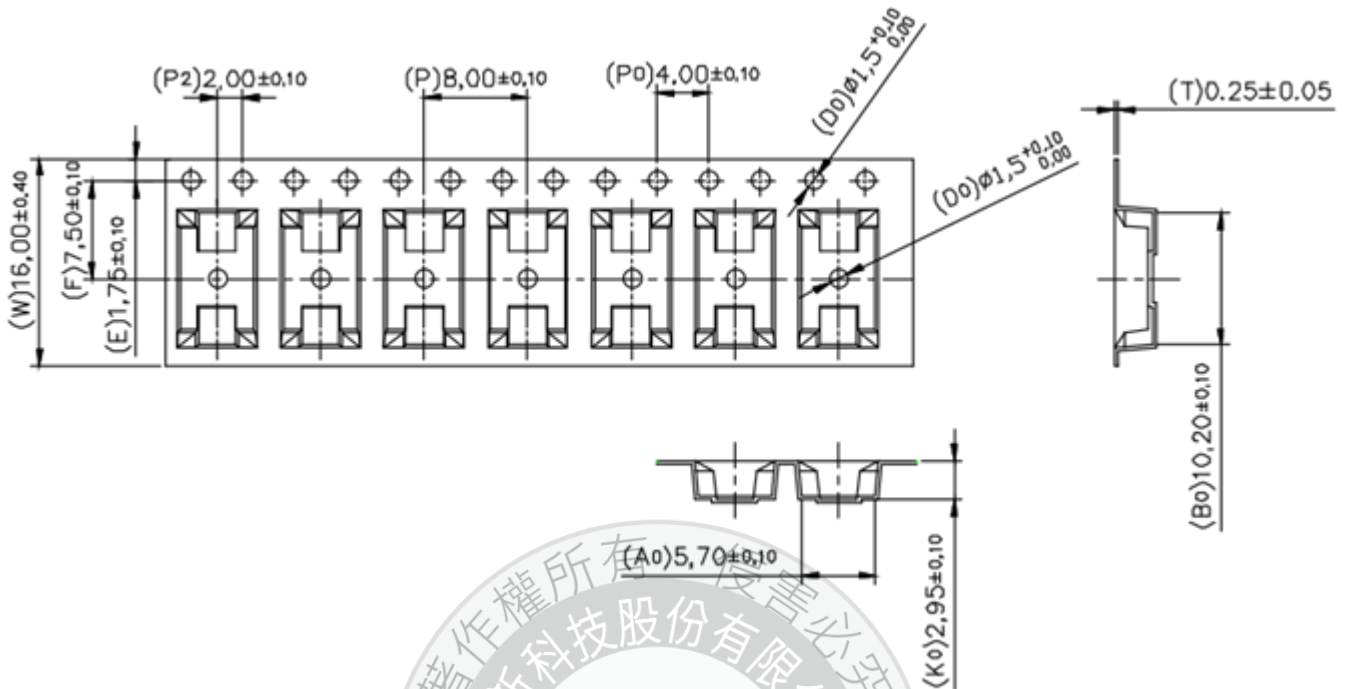

7.2 Reel Drawing

Q'ty/reel	reel size
3000pcs	13inch

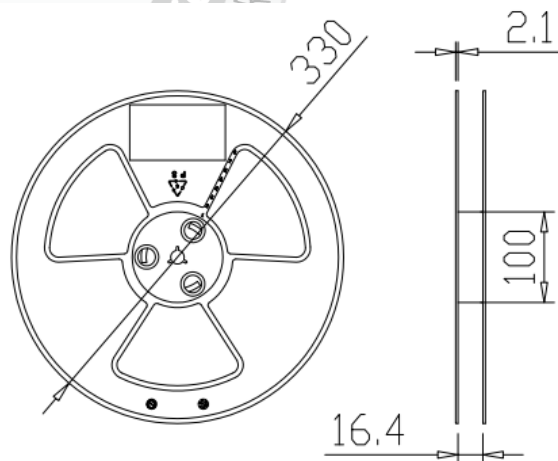

7.3 Product Packaging Scheme

Item	Data	Remark
Cover tape adhesion	10 ~ 100g	Carrier tape and cover tape open angle 165 ~ 180° F=300± 5mm/minute

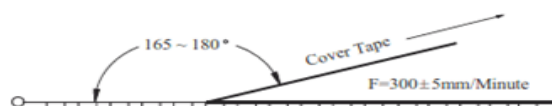

8. Soldering Recommendation:

8.1 Soldering Land Pattern Size:

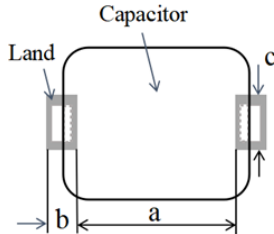

Package Dimension	a(mm)	b(mm)	c(mm)
7.8x5.4	8.0min	2.2±0.1	3.6±0.1

8.2 Reflow Soldering

When soldering capacitor, it should be performed in following conditions and the continuous welding times should not exceed three times.

Soldering temperature : 260±5°C.

Soldering time : 120s max.

Preheating temperature: 150°C max.

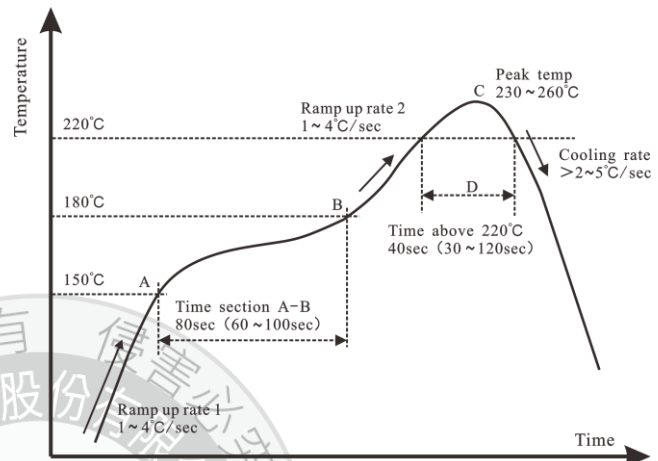

8.3 Wave Soldering

When soldering capacitor, it should be performed in following conditions and the continuous welding times should not exceed three times..

Soldering temperature : 260±5°C

Soldering time : 10s max.

Preheating temperature: 100°C max.

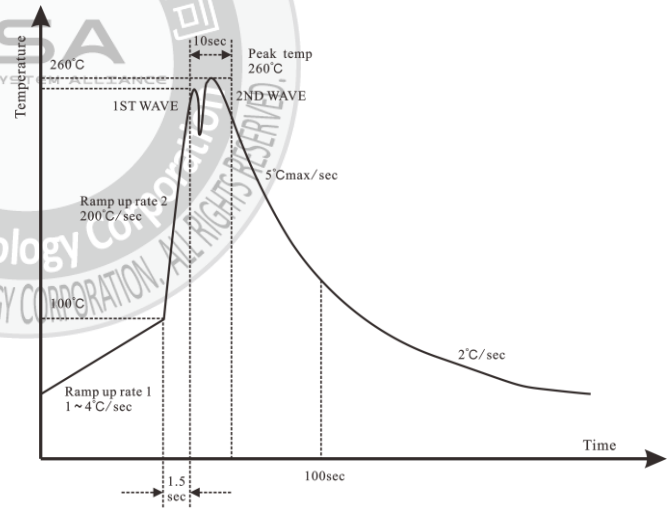

8.4 Soldering Iron

When soldering this product to a PCB/PWB, do not exceed the solder heat resistance specification of the capacitor. Subjecting this product to excessive heating could melt the internal junction solder and may result in thermal shocks that can crack the ceramic element.

When soldering capacitor with a soldering iron, it should be performed in following conditions.

Temperature of iron-tip : 400°C max.

Soldering iron wattage : 50W max.

Soldering time : 5s max.

9. Storage conditions

9.1 The insulating Epoxy molded capacitors does not form a perfect seal; therefore, do not use or store capacitors in a corrosive atmosphere, especially where chloride gas, sulfide gas, acid, alkali, salt or the like are present. And avoid exposure to moisture. So, in order to avoid the absorption of moisture, capacitors are packed in moisture-proof envelope.

9.2 Store the capacitors in the following conditions at all times, and use within 12 months after delivered. Temperature: 10 ~30°C Humidity: 60%max.

9.3 Solder the enclosed capacitors within 168 hours after opening the moisture-proof package. After opening, store the capacitors in moisture-proof package with a desiccant and HIC card and keep the above condition.

9.4 In case the storage period has been exceeded 12 months or the indicator color of a enclosed HIC card has changed when the package has been opened, perform baking (60°Cx168hr) before soldering.



Safety Standard Certified Resin Molding SMD Type Ceramic Capacitors for automotive SYW Series (Y1:250V~/400V~) 100J~222M _automotive	POE-D45-00-E-01	Ver: 10	Page: 16 / 18
--	-----------------	---------	---------------

10. Caution

10.1 Operating voltage

When DC-rated capacitors are to be used in AC or ripple current circuits, be sure to maintain the Vp-p value of the applied voltage or the Vo-p which contains DC bias within the rated voltage range.

When the voltage is started to apply to the circuit or it is stopped applying, the irregular voltage may be generated for a transit period because of resonance or switching. Be sure to use a capacitor within rated voltage containing these irregular voltage.

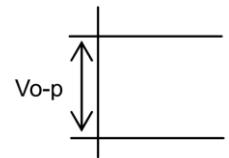
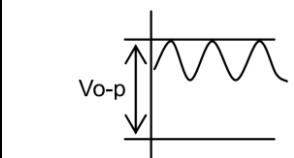
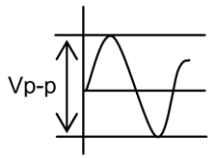
电压/Voltage	直流电压/DC Voltage	直流+交流电压/DC+AC Voltage	交流电压/AC Voltage
位置测量 / Positional measurement			

10.2 Operating temperature and self-generated heat

Keep the surface temperature of a capacitor below the upper limit of its rated operating temperature range. Be sure to take into account the heat generated by the capacitor itself.

10.3 Test condition for withstanding voltage

Test equipment : Test equipment for AC withstanding voltage should be used with the performance of the wave similar to 50/60 Hz sine wave.

Voltage applied method : When the withstanding voltage is applied, capacitor's lead or terminal should be firmly connected to the out-put of the withstanding voltage test equipment, and then the voltage should be raised from near zero to the test voltage.

If the test voltage without the raise from near zero voltage would be applied directly to capacitor, the surge voltage may arise, and therefore the defective may be caused.

*ZERO CROSS is the point where voltage sine wave pass 0V.

10.4 Fail-Safe

When capacitor would be broken, failure may result in a short circuit. Be sure to provide an appropriate fail-safe function like a fuse on your product if failure would follow an electric shock, fire or fume.

10.5 Vibration and impact

Do not expose a capacitor or its leads to excessive shock or vibration during use. Excessive shock or vibration may cause to fatigue destruction of lead wires mounted on the circuit board. Please take measures to hold a capacitor on the circuit boards by adhesive, molding resin or coating and other.

Please confirm there is no influence of holding measures on the product with a intended equipment.

10.6 Bonding, resin molding and coating

In case of bonding, molding or coating this product, verify that these processes do not affect the quality of capacitor by testing the performance of the bonded, molded or coated product in the intended equipment.

In case of the amount of applications, dryness / hardening conditions of adhesives and molding resins containing organic solvents (ethyl acetate, methyl ethyl ketone, toluene, etc.) are unsuitable, the outer coating resin of a capacitor is damaged by the organic solvents and it may result, worst case, in a short circuit.

The variation in thickness of adhesive, molding resin or coating may cause an outer coating resin cracking and/or ceramic element cracking of a capacitor in a temperature cycling.

10.7 Treatment after bonding, resin molding and coating

When the outer coating is hot (over 100°C) after soldering, it becomes soft and fragile. So please be careful not to give it mechanical stress. Failure to follow the above cautions may result, worst case, in a short circuit and cause fuming or partial dispersion when the product is used.

10.8 Limitation of applications

Please contact us before using our products for the applications listed below which require especially high reliability for the prevention of defects which might directly cause damage to the third party's life, body or property.

- (1) Aircraft equipment
- (2) Aerospace equipment
- (3) Undersea equipment
- (4) Power plant control equipment
- (5) Medical equipment
- (6) Transportation equipment (vehicles, trains, ships, etc.)
- (7) Traffic signal equipment
- (8) Disaster prevention / crime prevention equipment
- (9) Data-processing equipment exerting influence on public
- (10) Application of similar complexity and/or reliability requirements to the applications listed in the above.

11 Notices

11.1 Cleaning (ultrasonic cleaning):

To perform ultrasonic cleaning, observe the following conditions.

Rinse bath capacity : Output of 20 watts per liter or less.

Rinsing time : 5 min maximum.

Do not vibrate the PCB/PWB directly.

Excessive ultrasonic cleaning may lead to fatigue destruction of the lead wires.

11.2 Capacitance change of capacitors

Class 2 and 3 capacitors like temperature characteristic B, E and F have an aging characteristic, whereby the capacitor continually decreases its capacitance slightly if the capacitor leaves for a long time. Moreover, capacitance might change greatly depending on a surrounding temperature or an applied voltage. So, it is not likely to be able to use for the time constant circuit.

11.3 Performance check by equipment

Before using a capacitor, check that there is no problem in the equipment's performance and the specifications.

Generally speaking, CLASS 2 ceramic capacitors have voltage dependence characteristics and temperature dependence characteristics in capacitance. So, the capacitance value may change depending on the operating condition in a equipment. Therefore, be sure to confirm the apparatus performance of receiving influence in a capacitance value change of a capacitor, such as leakage current and noise suppression characteristic.

Moreover, check the surge-proof ability of a capacitor in the equipment, if needed, because the surge voltage may exceed specific value by the inductance of the circuit.

11.4 Please make sure that your product has been evaluated in view of your specifications with our product being mounted to your product.

11.5 You are requested not to use our product deviating from this specification.